

1.5" NAIL STRIP

RECOMMENDED DETAILS AND TRIMS

RELIABLE SHEET METAL, INC.
1041 16TH AVENUE
BYRON CENTER, MI 49315

PHONE: 616-896-9427
FAX: 616-896-9887
WWW.RELIABLESM.COM

LOW EAVE / GUTTER

- 1.) Temporarily attach gutter at ends w/ #10-12 x 1" pancake head wood screws
- 2.) Apply butyl sealant across top of gutter as shown.
- 3.) Attach cleat through sealant w/ #10-12 x 1" pancake head wood screws @ 4"oc.
- 4.) Apply a second bead of butyl sealant across the top of the cleat, and over the fastener heads.
- 5.) Install panels so that the cleat is engaged into the field applied hem.

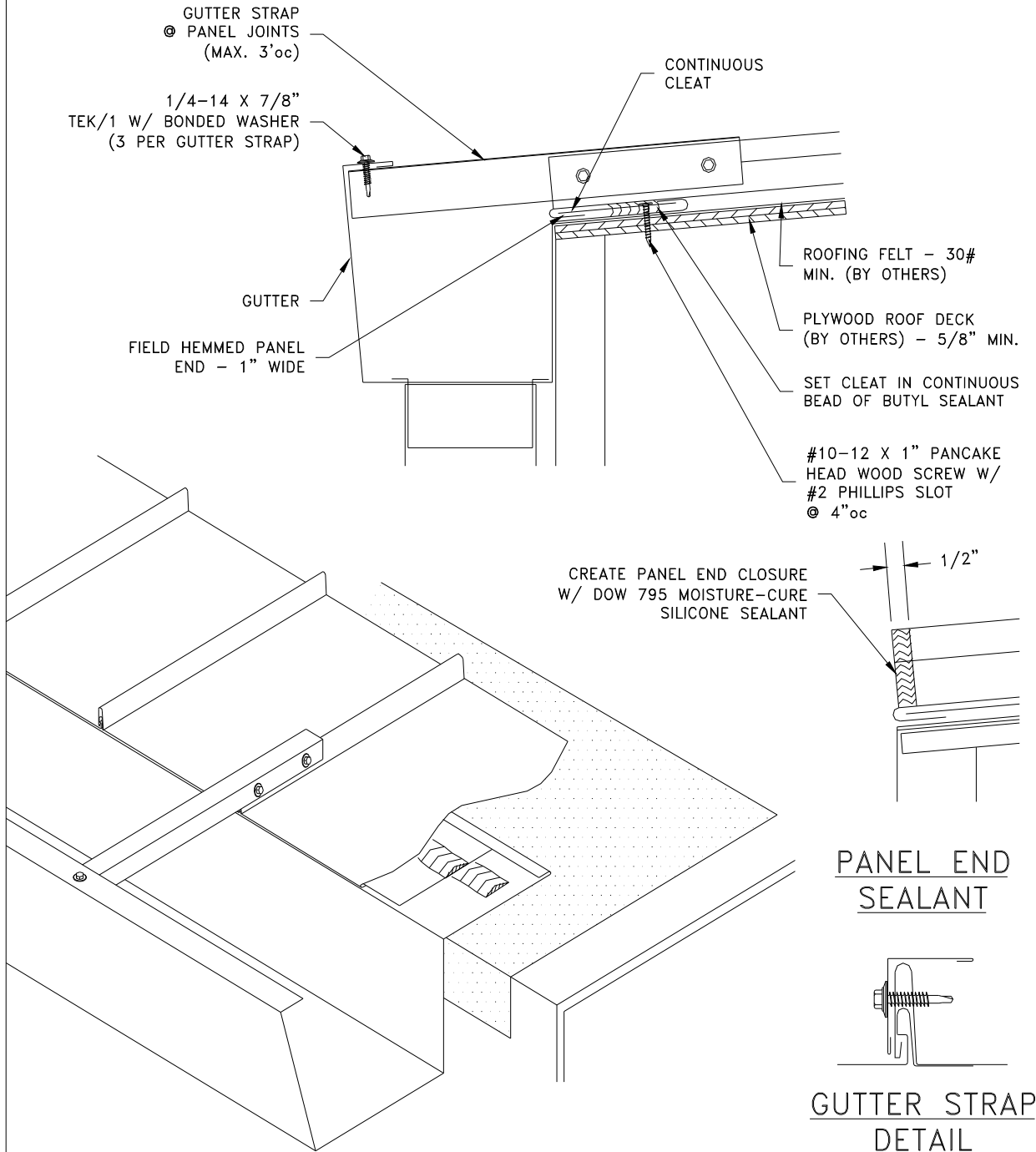

HIGH EAVE

- 1.) Determine location of zee closure. Apply sealant tape to flat of panel.
- 2.) Place closure on top of sealant tape. Secure through tape and panel with #9-16 x 1" HWH wood screws @ 4"oc. Seal the tab of the closure to the side joints with butyl sealant.
- 3.) Apply a continuous strip of sealant tape to the top of the zee closure. Seal between ends of tape with butyl sealant.
- 4.) Install the high eave trim. Secure to closure zee with 1/4-14 x 7/8" HWH Tek/1 fasteners at 12"oc.

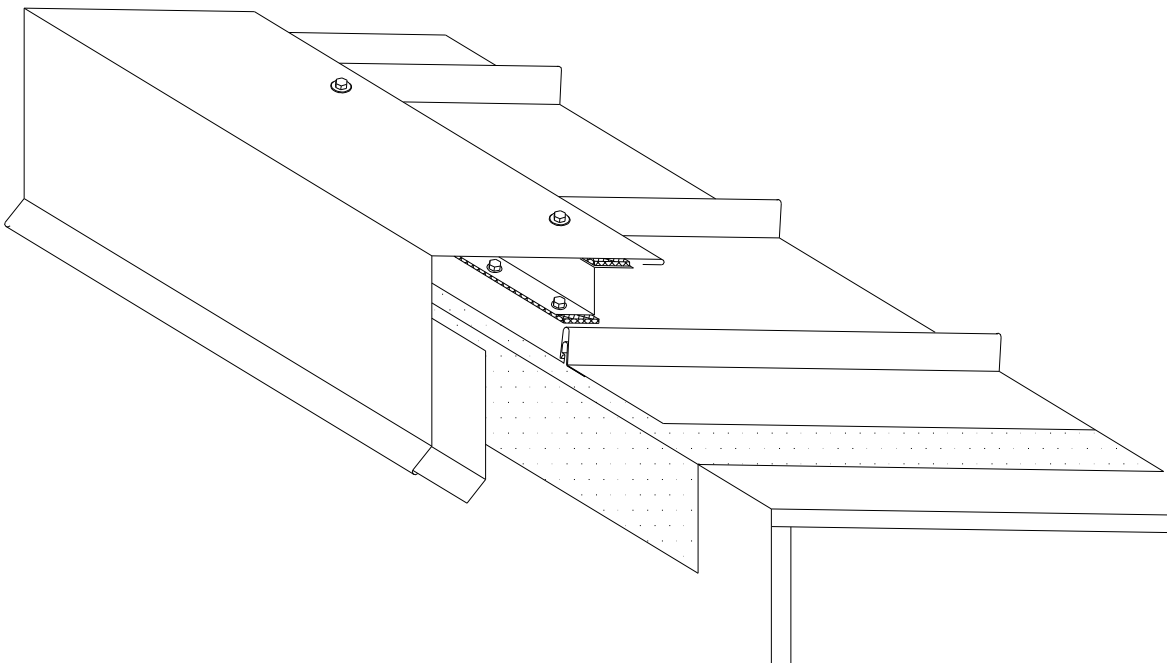
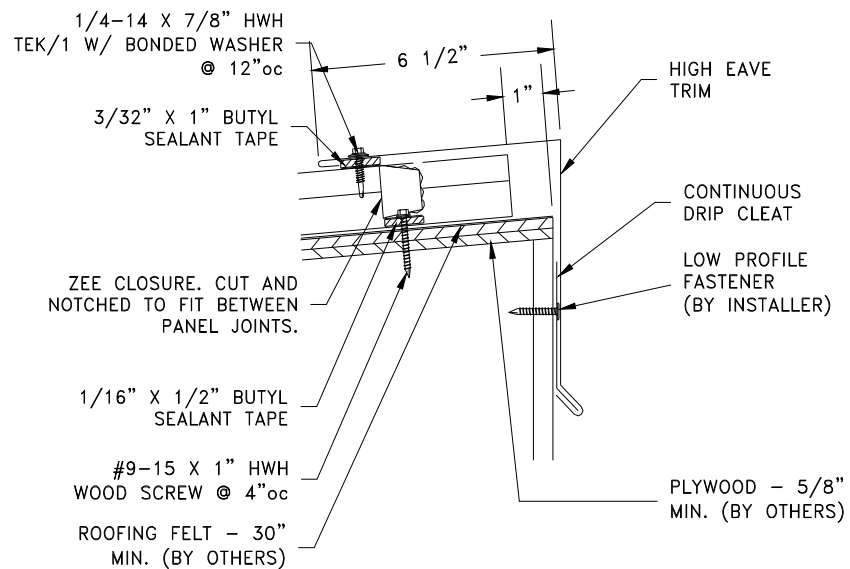

FIELD HEMMED PANEL END

CUT FEMALE END
BACK 1"

1. PANELS REQUIRING FIELD HEMMED ENDS SHOULD BE FABRICATED 1" LONGER THAN THE FINISHED PANEL LENGTH. VALLEY CONDITIONS MUST BE FIELD CUT TO THE APPROPRIATE ANGLE

2. CUT BACK PANEL JOINTS 1"

CUT MALE END
BACK 1"

3. PLACE PROTRUDING PAN INTO THE PANEL HEMMING TOOL. THE FRONT EDGE OF THE TOOL MUST REST AGAINST THE NOTCHED JOINT LEGS ON BOTH SIDES.

4. WHILE MAINTAINING PRESSURE AGAINST THE PANEL JOINTS, ROTATE THE HEMMING TOOL AS CLOSE TO 180° AS POSSIBLE.

PANEL HEMMING TOOL

5. INSPECT COMPLETED HEM TO INSURE THAT THE HEM IS OPENED AND CAPABLE OF RECEIVING THE CLEAT (SEE ERECTION DETAILS).

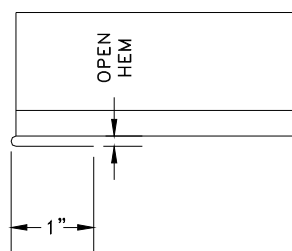

LOW EAVE

- 1.) Temporarily attach eave trim at ends w/ #10-12 x 1" pancake head wood screws
- 2.) Apply butyl sealant across top of eave trim as shown.
- 3.) Attach cleat through sealant w/ #10-12 x 1" pancake head wood screws @ 4"oc.
- 4.) Apply a second bead of butyl sealant across the top of the cleat, and over the fastener heads.
- 5.) Install panels so that the cleat is engaged into the field applied hem.

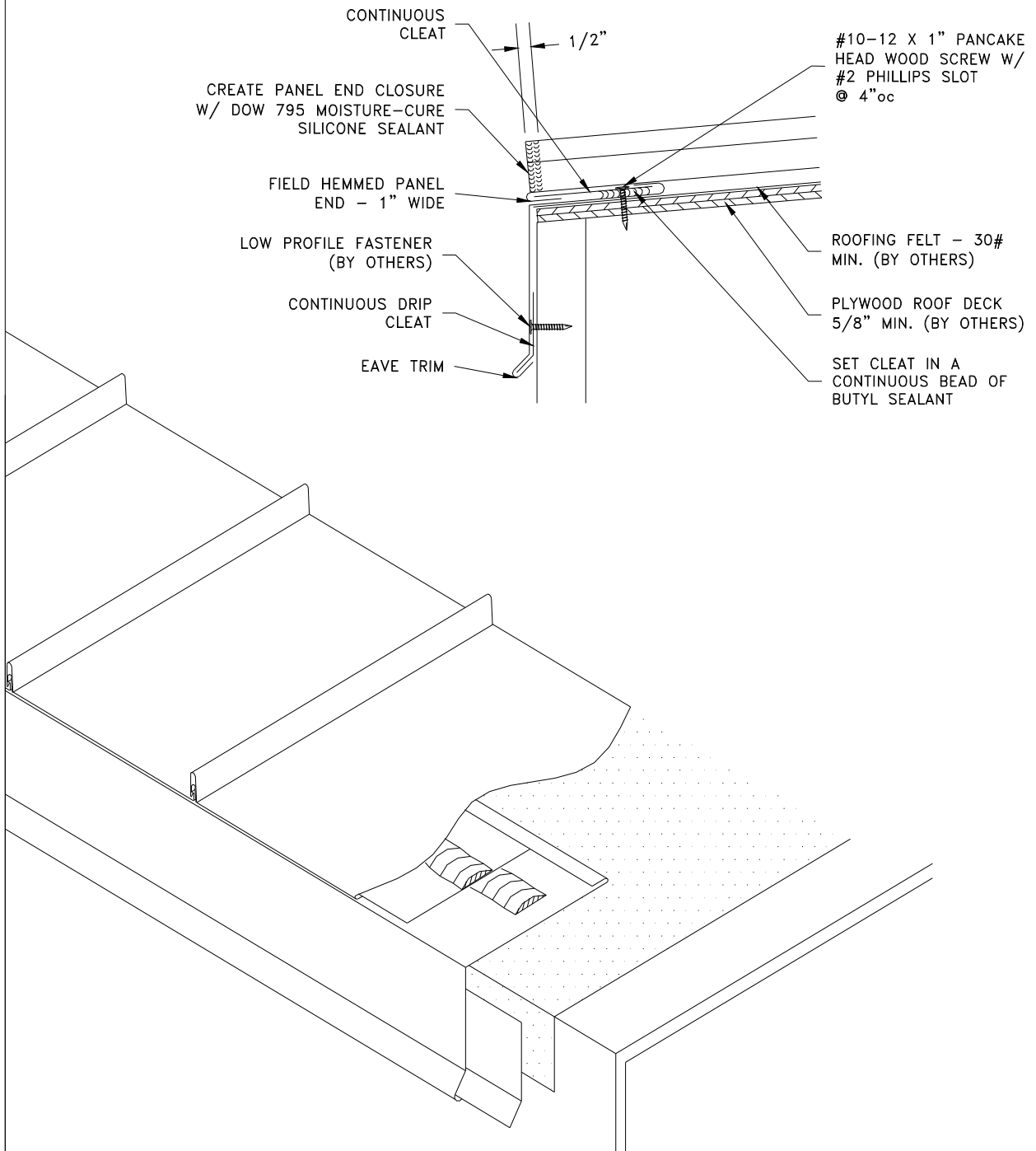

PANEL PROPERTIES

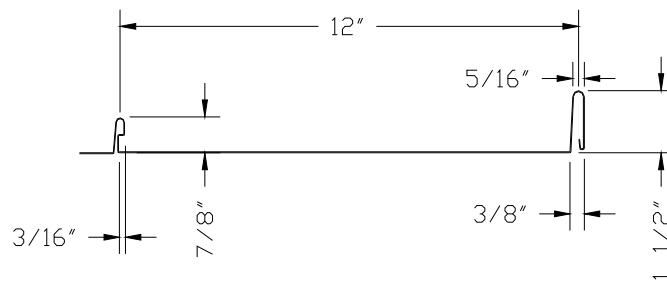

1.5" NAILSTRIP

EFFECTIVE SECTION PROPERTIES FOR 12" WIDE PANELS

GAGE	+I (in ³)	+S (in ⁴)	-I (in ³)	-S (in ⁴)	R (allow) 1.0' to 1.75'	R (allow) 2.0' to 2.75'	R (allow) 3.0' to 4.0'
24 (.024")	0.026	0.038	0.023	0.039	71.6 #/ft	84.5 #/ft	99.3#/ft

Use (+) I (eff) for deflection considerations when the panel is experiencing downward (positive) loading normal to the plane of the roof.

Use (-) I (eff) for deflection considerations when the panel is experiencing upward (negative) loading normal to the plane of the roof.

Use R (allowable) for the consideration of panel edge fastener tearout under upward (negative) loading normal to the plane of the roof.

PANEL JOINT AND ATTACHMENT DETAIL

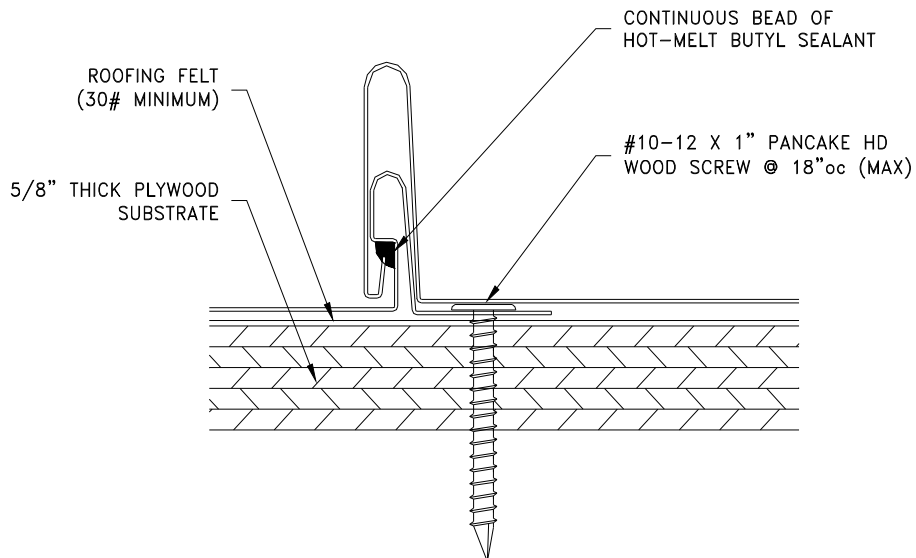

RAKE

- 1.) Temporarily attach the rake trim at ends w/ #10-12 x 1" pancake head wood screws.
- 2.) Attach receiver through rake trim w/ #10-12 x 1" pancake head wood screw @ 12"OC.
- 3.) Apply butyl sealant over the heads of the wood screws as shown.
- 4.) Apply urethane sealant inside the open hem of the receiver trim.
- 5.) Install panels so that the the field cut end is engaged into the open hem of the receiver trim, and fully embedded into the urethane sealant.
- 6.) Apply urethane sealant between the receiver and the rake trim. Tool to a fillet.

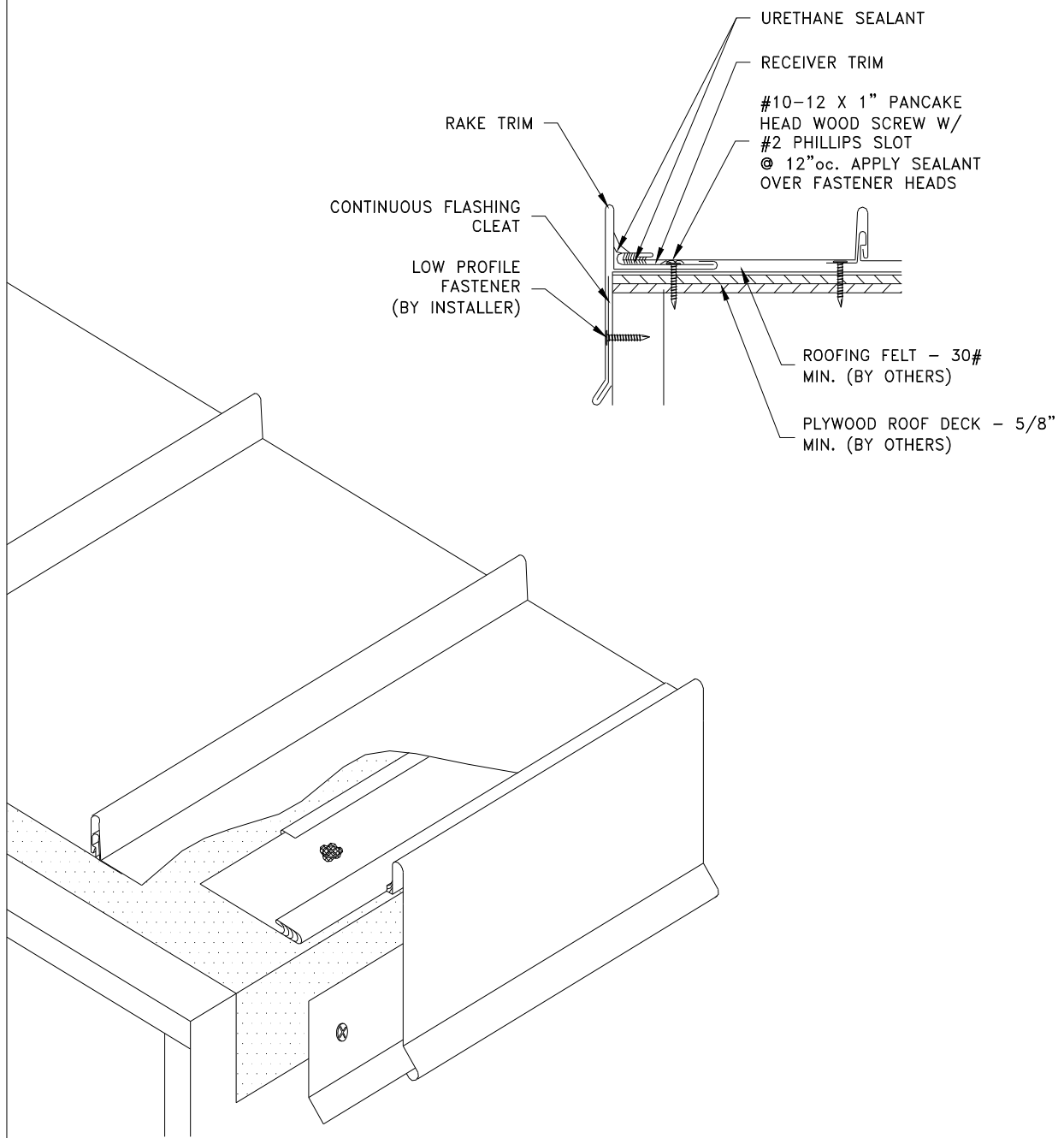

HIGH PROFILE RAKE

- 1.) Turn cut edge of panel up 1".
- 2.) Determine location off zee closure. Apply sealant tape to flat of panel.
- 3.) Place closure on top of sealant tape. Secure through tape and panel with #10-12 x 1" HWH wood screws @ 12"oc.
- 4.) Apply a continuous strip of sealant tape to the top of the zee closure. Seal between ends of tape with butyl sealant.
- 5.) Install panels so that the the field cut end is engaged into the open hem of the receiver trim, and fully embedded into the urethane sealant.
- 6.) Install the rake trim. Secure to closure zee with 1/4-14 x 7/8" HWH Tek/1 fasteners at 12"oc.

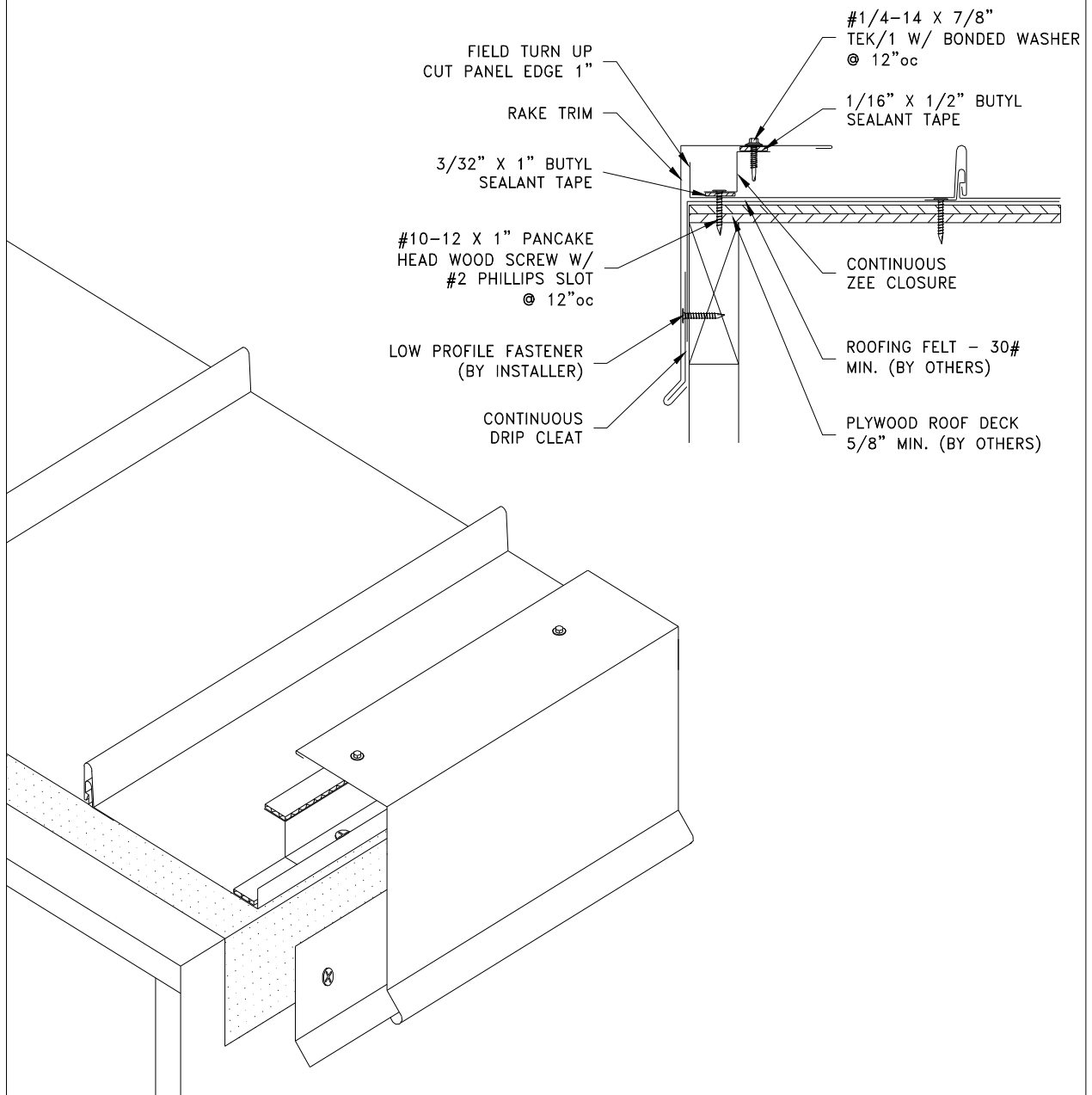

RIDGE / HIP

- 1.) Determine location of zee closure. Apply sealant tape to flat of panel.
- 2.) Place closure on top of sealant tape. Secure through tape and panel with #9-16 x 1" HWH wood screws @ 4"oc. Seal the tab of the closure to the side joints with butyl sealant.
- 3.) Apply a continuous strip of sealant tape to the top of the zee closure. Seal between ends of tape with butyl sealant.
- 4.) Install the ridge trim. Secure to closure zee with 1/4-14 x 7/8" HWH Tek/1 fasteners at 12"oc.

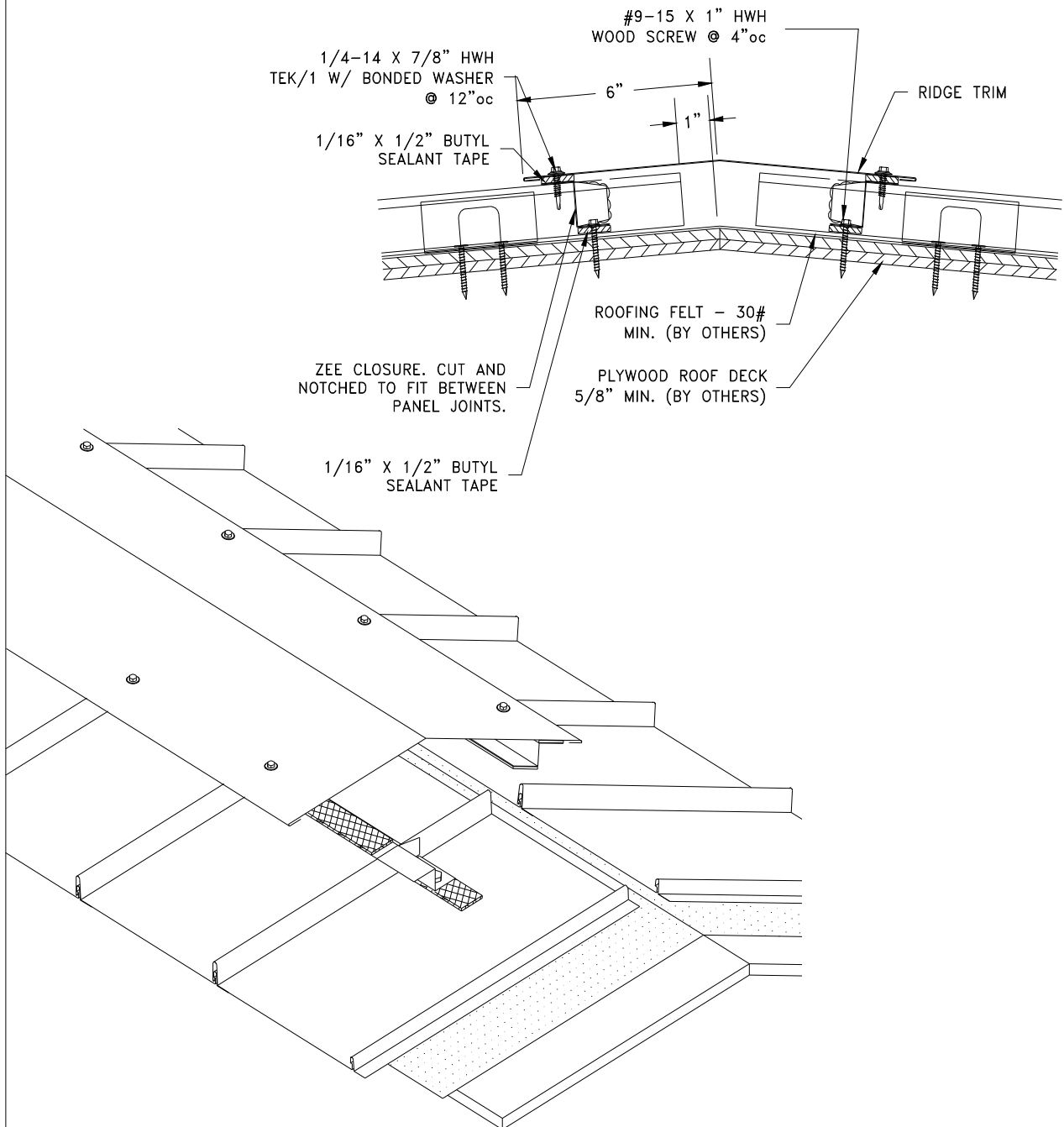

HIGH EAVE TRANSITION

- 1.) Determine location of zee closure. Apply sealant tape to flat of panel.
- 2.) Place closure on top of sealant tape. Secure through tape and panel with #9-16 x 1" HWH wood screws @ 4"oc. Seal the tab of the closure to the side joints with butyl sealant.
- 3.) Apply a continuous strip of sealant tape to the top of the zee closure. Seal between ends of tape with butyl sealant.
- 4.) Install the transition trim. Secure to closure zee with 1/4-14 x 7/8" HWH Tek/1 fasteners at 12"oc.
- 5.) Fill open hem of counter flash with urethane sealant. Interlock the two trims and secure counter flash to wall with the appropriate fastener.

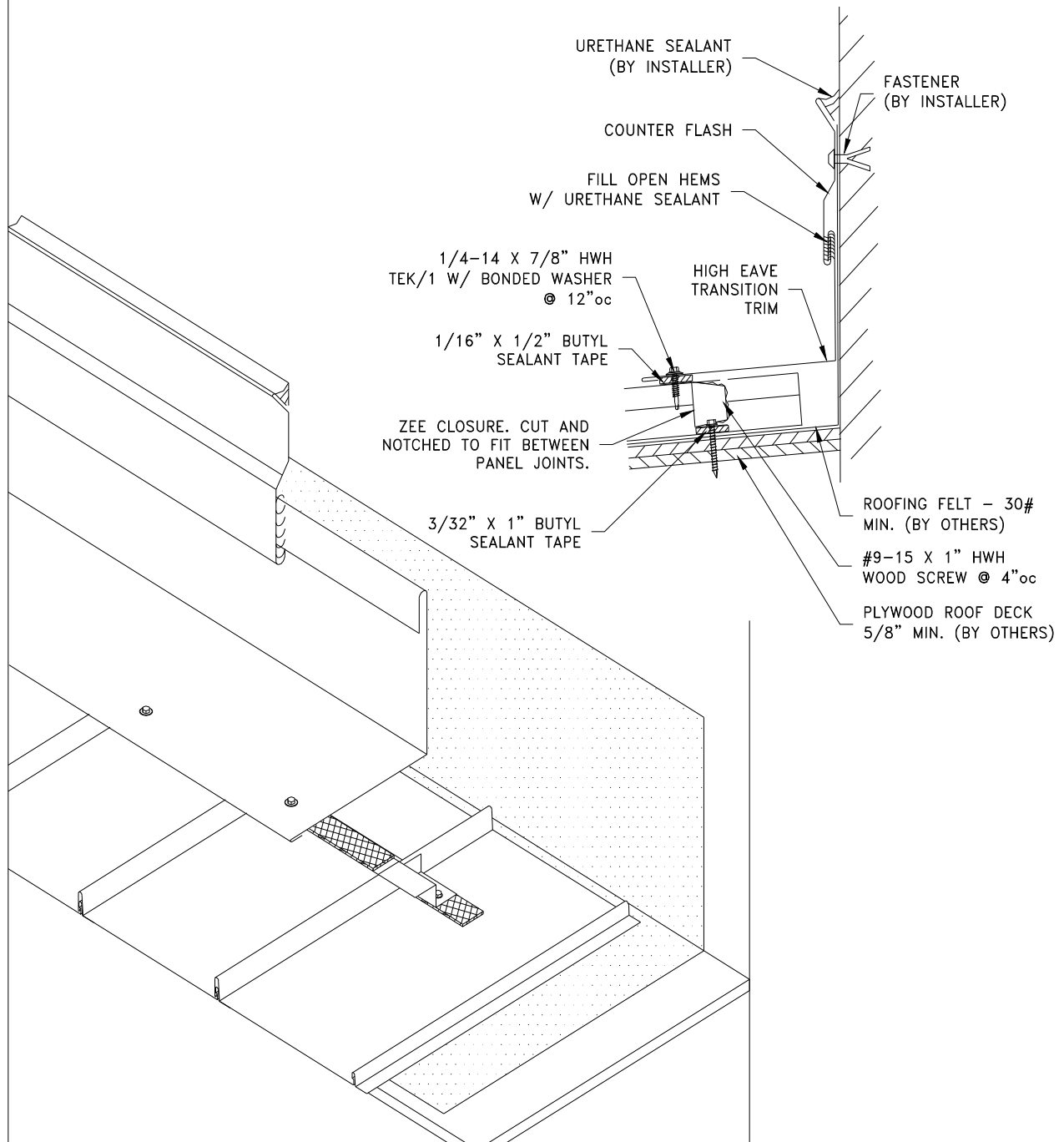

RAKE WALL TRANSITION

- 1.) Temporarily attach transition trim at ends w/ #10-12 x 1" pancake head wood screws
- 2.) Attach receiver through transition with #10-12 x 1" pancake head wood screws @ 12"oc.
- 3.) Apply butyl sealant over the heads of the wood screws. as shown.
- 4.) Apply a bead of urethane sealant inside the open hem of the receiver trim.
- 5.) Install panels so that the field cut end is engaged into open hem of the receiver trim, and fully embedded into the urethane sealant.
- 6.) Apply urethane sealant between the receiver and the transition trim. Tool to a fillet.

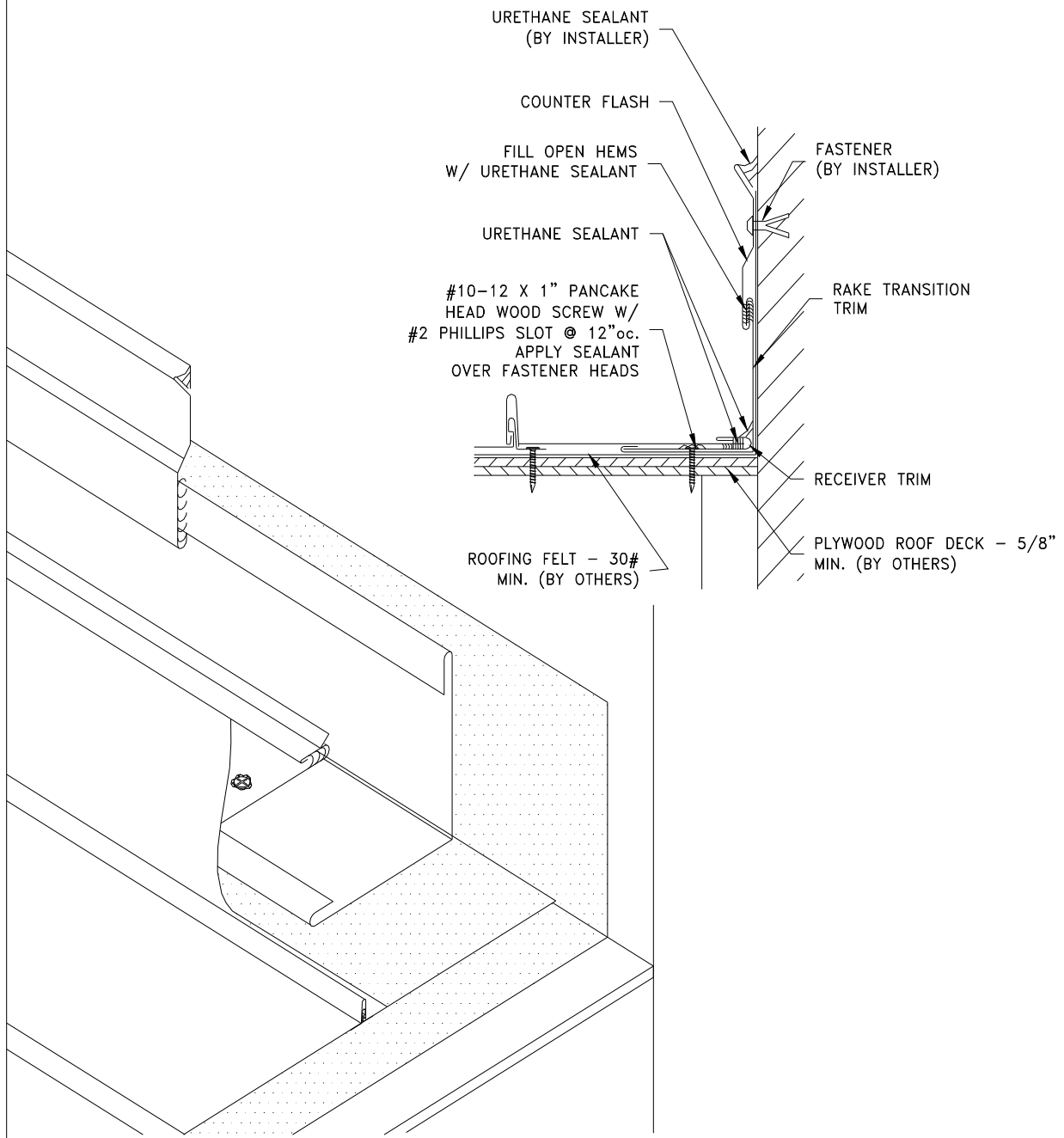

RIDGE / HIP

- 1.) Determine location of zee closure. Apply sealant tape to flat of panel.
- 2.) Place closure on top of sealant tape. Secure through tape and panel with #9-16 x 1" HWH wood screws @ 4"oc. Seal the tab of the closure to the side joints with butyl sealant.
- 3.) Apply a continuous strip of sealant tape to the top of the zee closure. Seal between ends of tape with butyl sealant.
- 4.) Install the ridge trim. Secure to closure zee with 1/4-14 x 7/8" HWH Tek/1 fasteners at 12"oc.

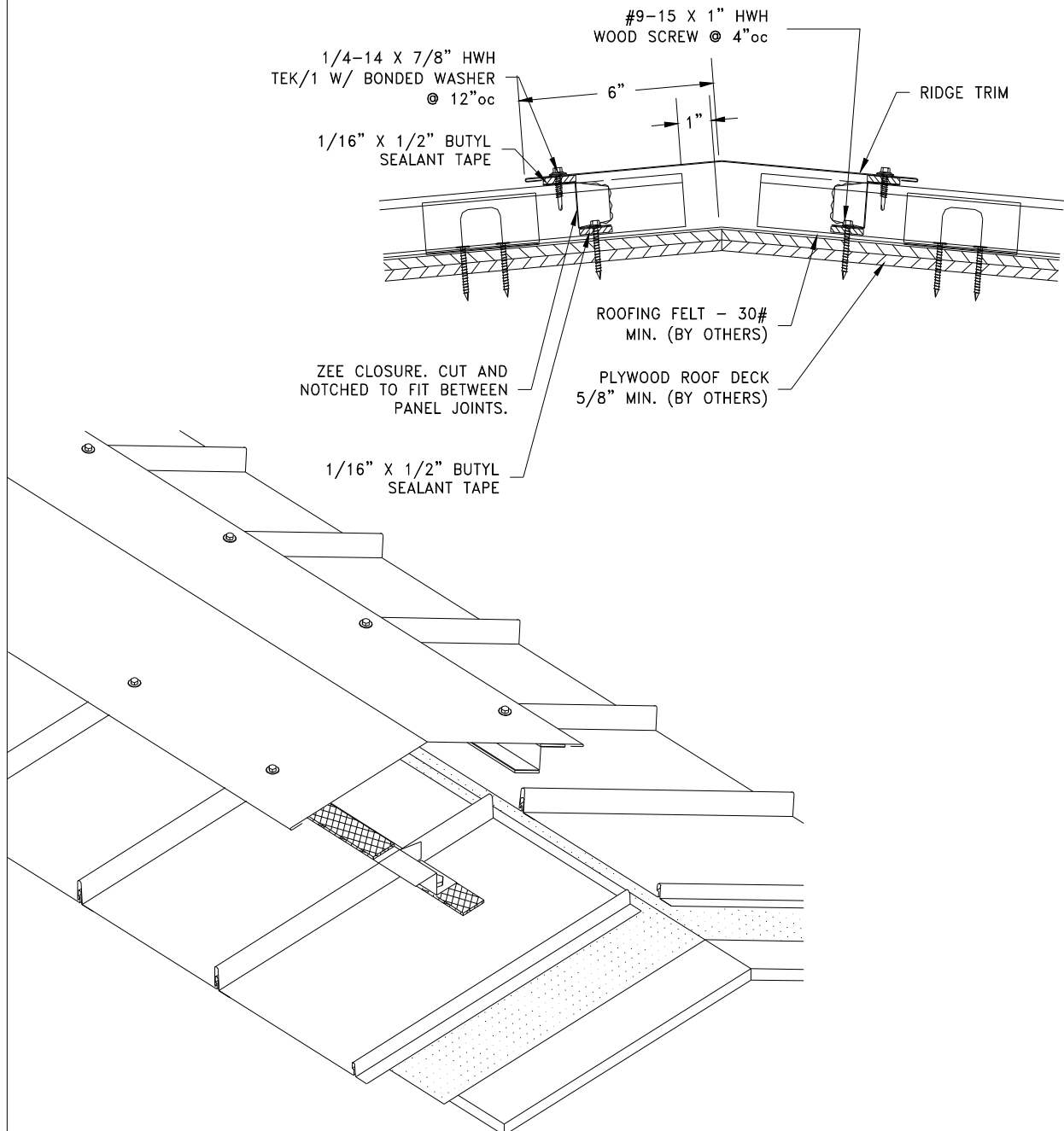

HIGH EAVE TRANSITION

- 1.) Determine location of zee closure. Apply sealant tape to flat of panel.
- 2.) Place closure on top of sealant tape. Secure through tape and panel with #9-16 x 1" HWH wood screws @ 4"oc. Seal the tab of the closure to the side joints with butyl sealant.
- 3.) Apply a continuous strip of sealant tape to the top of the zee closure. Seal between ends of tape with butyl sealant.
- 4.) Install the transition trim. Secure to closure zee with 1/4-14 x 7/8" HWH Tek/1 fasteners at 12"oc.
- 5.) Fill open hem of counter flash with urethane sealant. Interlock the two trims and secure counter flash to wall with the appropriate fastener.

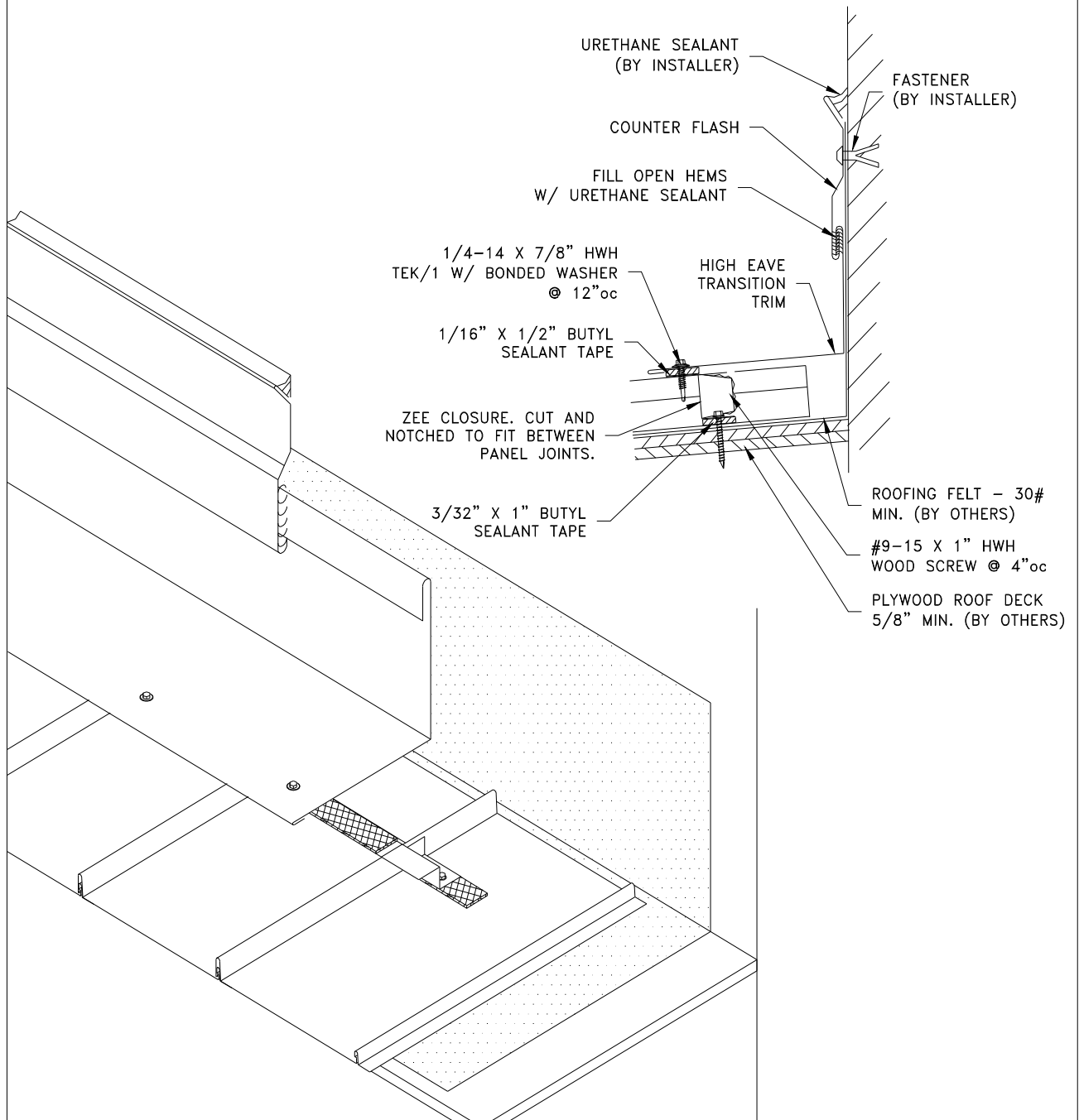

RAKE WALL TRANSITION

- 1.) Temporarily attach transition trim at ends w/ #10-12 x 1" pancake head wood screws
- 2.) Attach receiver through transition with #10-12 x 1" pancake head wood screws @ 12"oc.
- 3.) Apply butyl sealant over the heads of the wood screws. as shown.
- 4.) Apply a bead of urethane sealant inside the open hem of the receiver trim.
- 5.) Install panels so that the field cut end is engaged into open hem of the receiver trim, and fully embedded into the urethane sealant.
- 6.) Apply urethane sealant between the receiver and the transition trim. Tool to a fillet.

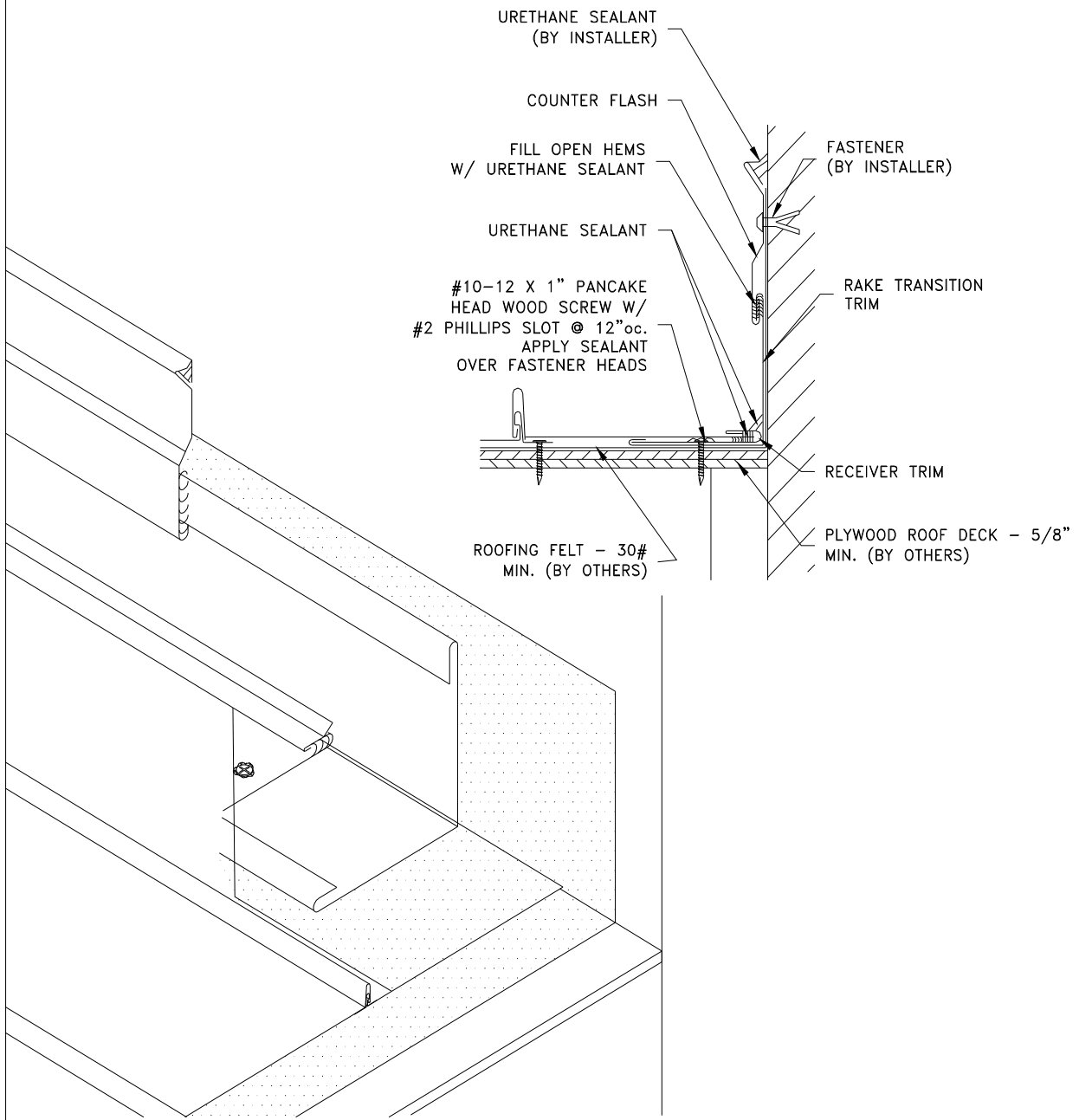

TRIMS

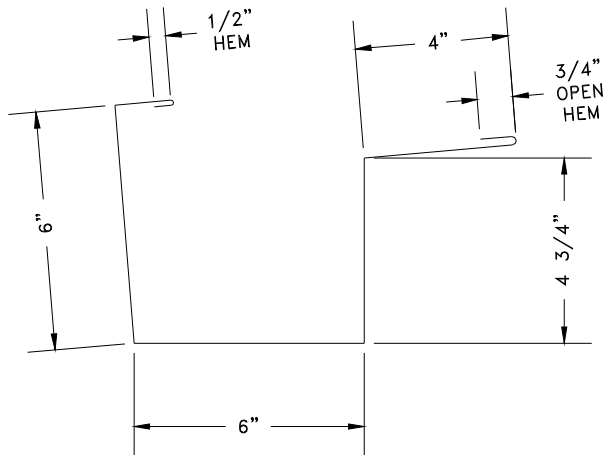

GUTTER

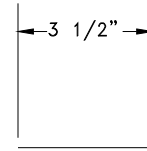

CLEAT

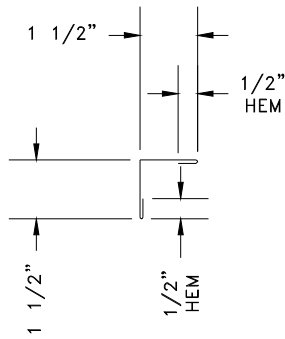

HIGH EAVE

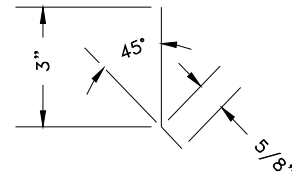

DRIP CLEAT

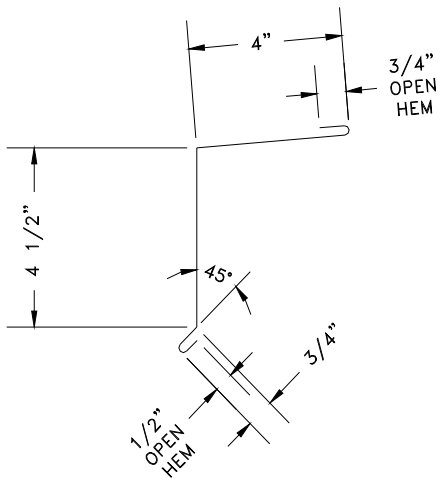

EAVE

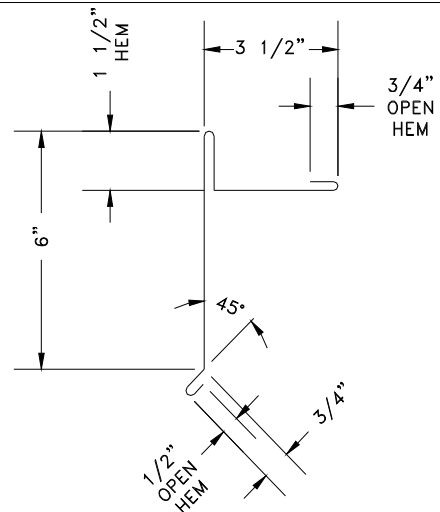

RAKE

TRIMS

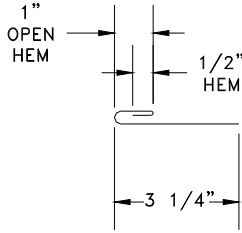

RECEIVER

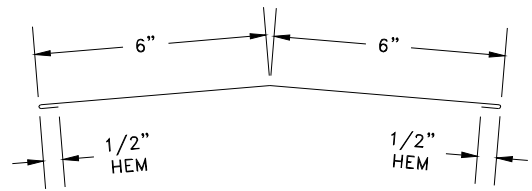

RIDGE / HIP

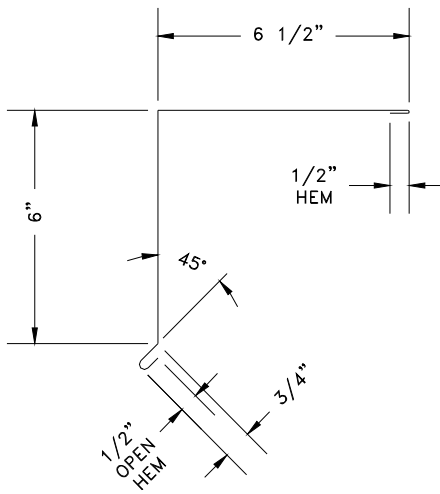

HIGH PROFILE RAKE

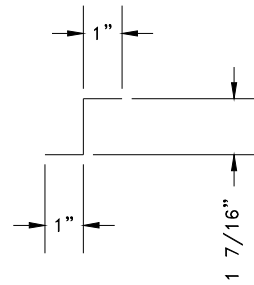

RAKE CLOSURE

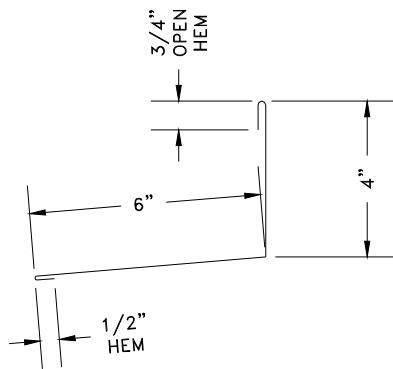

HIGH EAVE TRANSITION

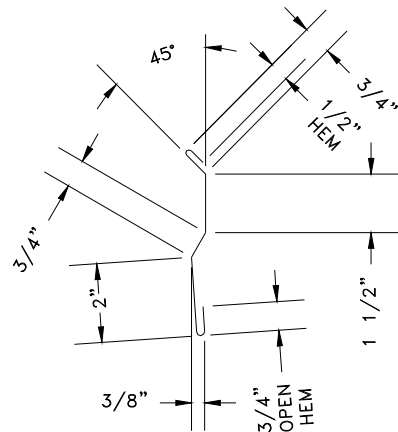

COUNTER FLASH

TRIMS

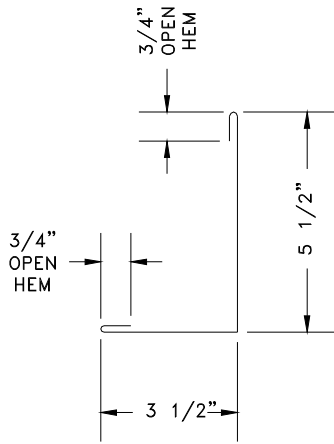

RAKE TRANSITION

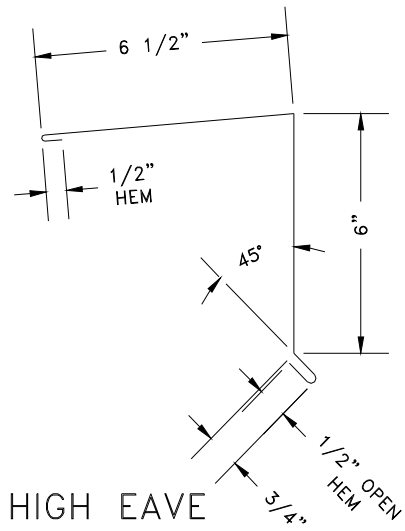

HIGH EAVE

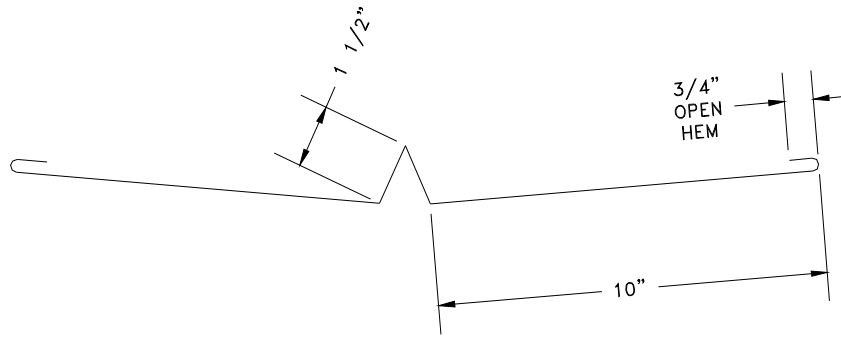

VALLEY

VALLEY

- 1.) Temporarily attach valley trim at ends w/ #10-12 x 1" pancake head wood screws.
- 2.) Apply butyl sealant across top of valley trim as shown.
- 3.) Attach cleat through sealant w/ #10-12 x 1" pancake head wood screws @ 4"oc.
- 4.) Apply a second bead of butyl sealant across the top of the cleat, and over the fastener heads.
- 5.) Install panels so that the cleat is engaged into the field applied hem.

